

T21



BERETTA[®]
HYDRAULIC DRILLING RIGS

T21-R

T21 (DIESEL or ELECTRIC VERSION) & (RADIO or MANUAL)

HYDRAULIC DRILLING RIGS

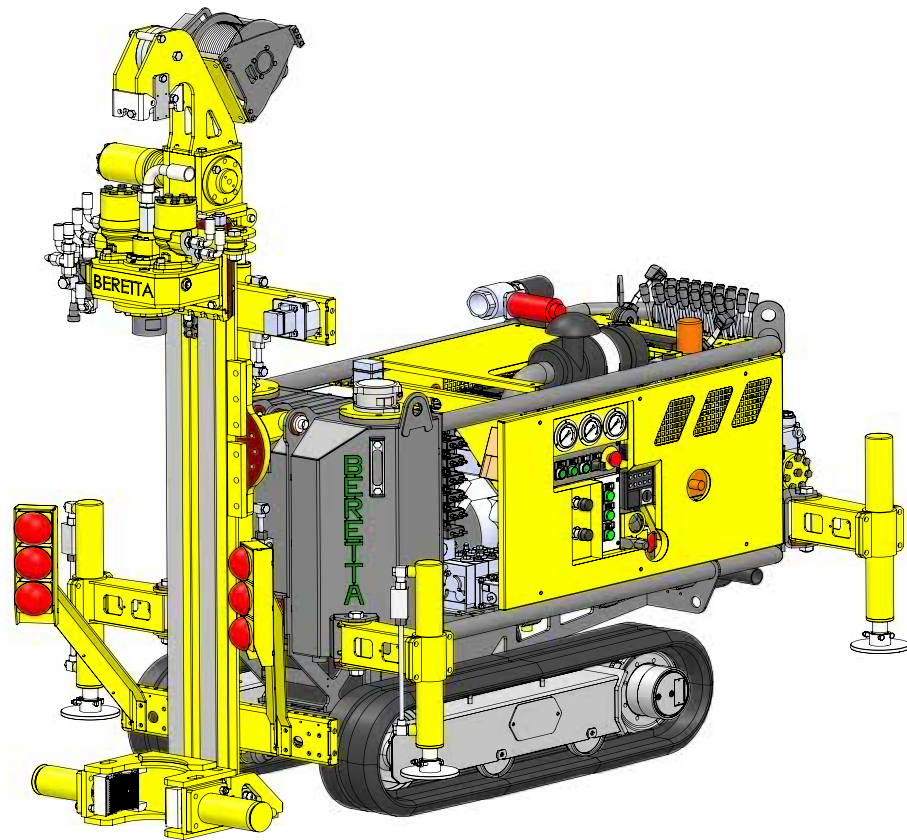

MACHINE DESCRIPTIONS

Weight: 1100 Kg (full opt. up to 1350 Kg)

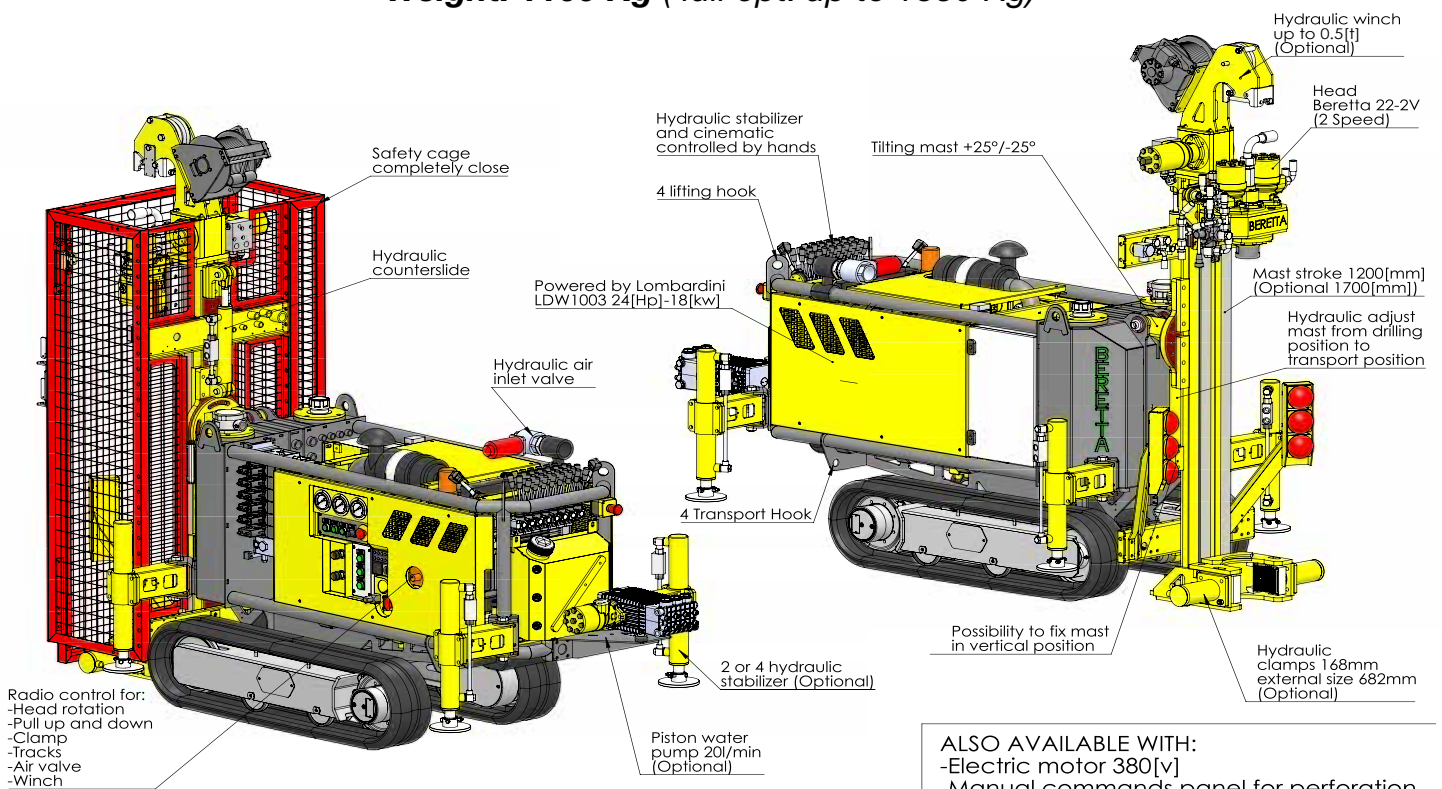

OVERALL DIMENSIONS

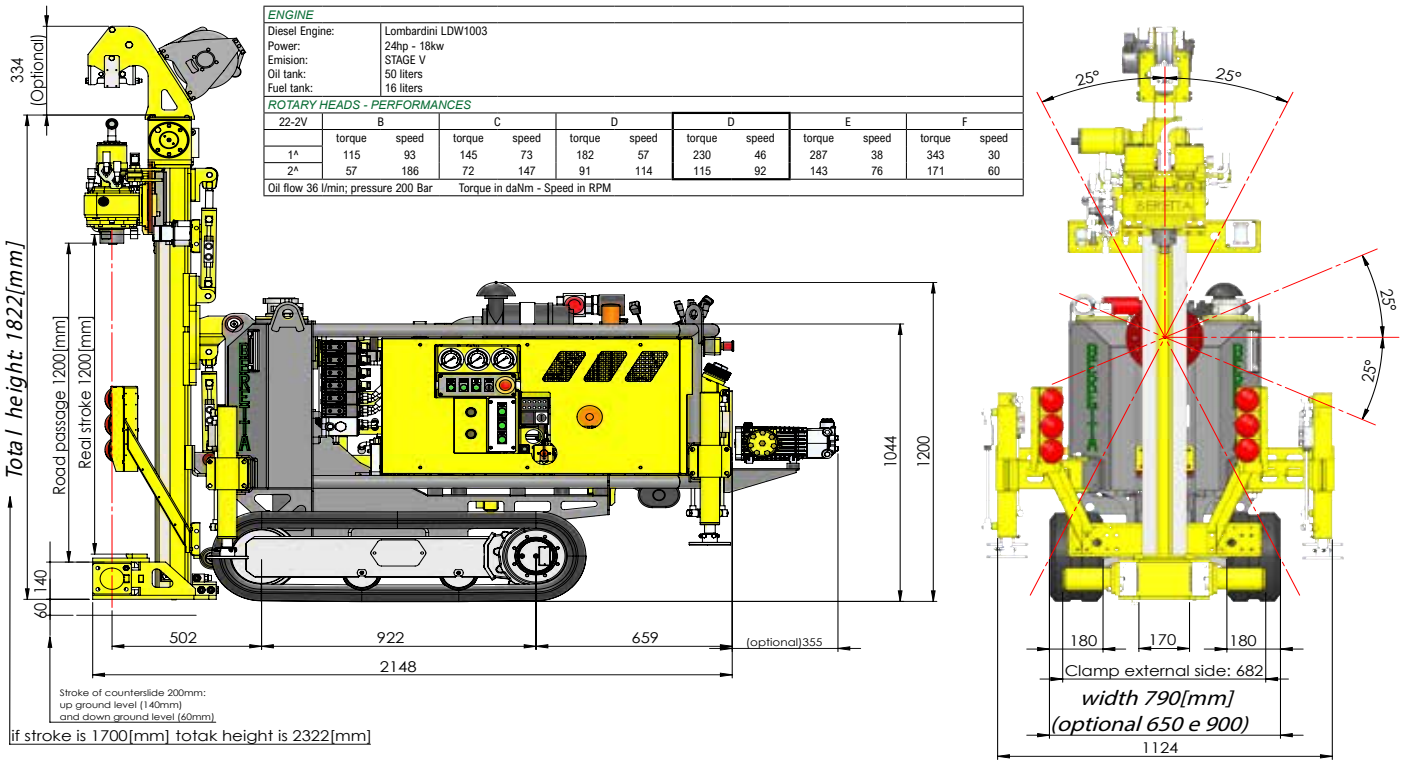

TRANSPORT DIMENSIONS

Weight: 1100 Kg (full opt. up to 1350 Kg)

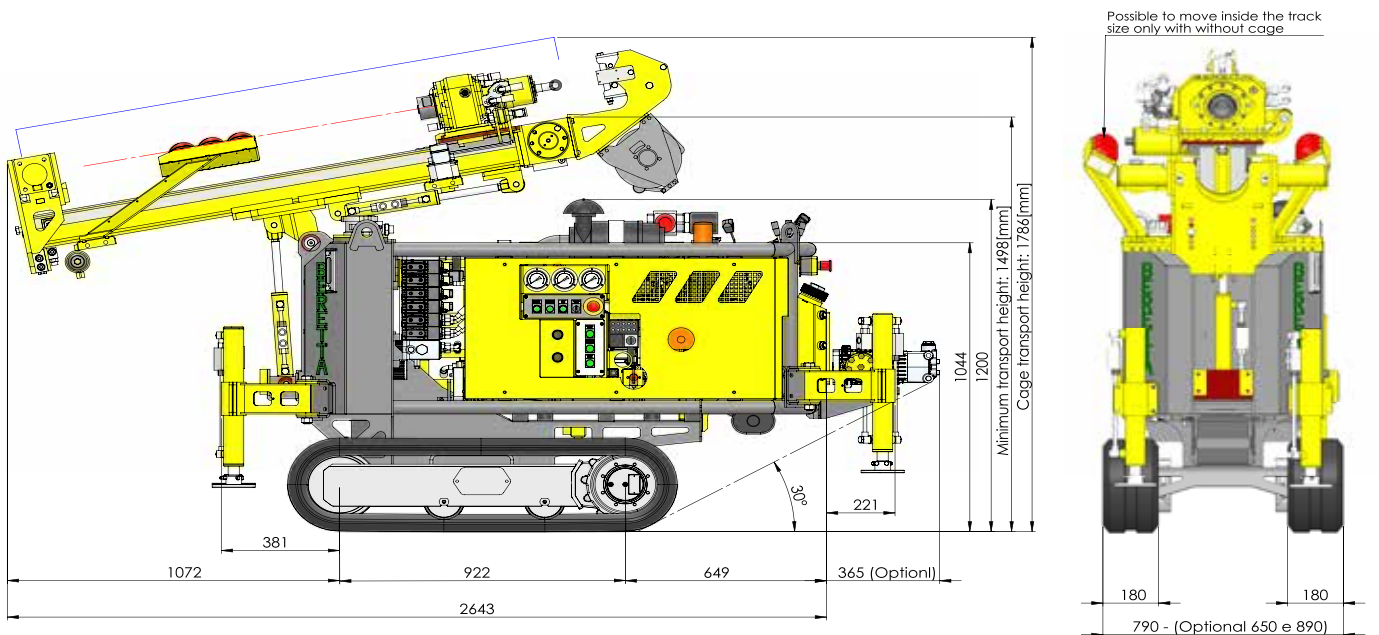

T21-R

T21 MAST STROKE 1700 mm (with drilling panel or radio)

OVERALL DIMENSIONS

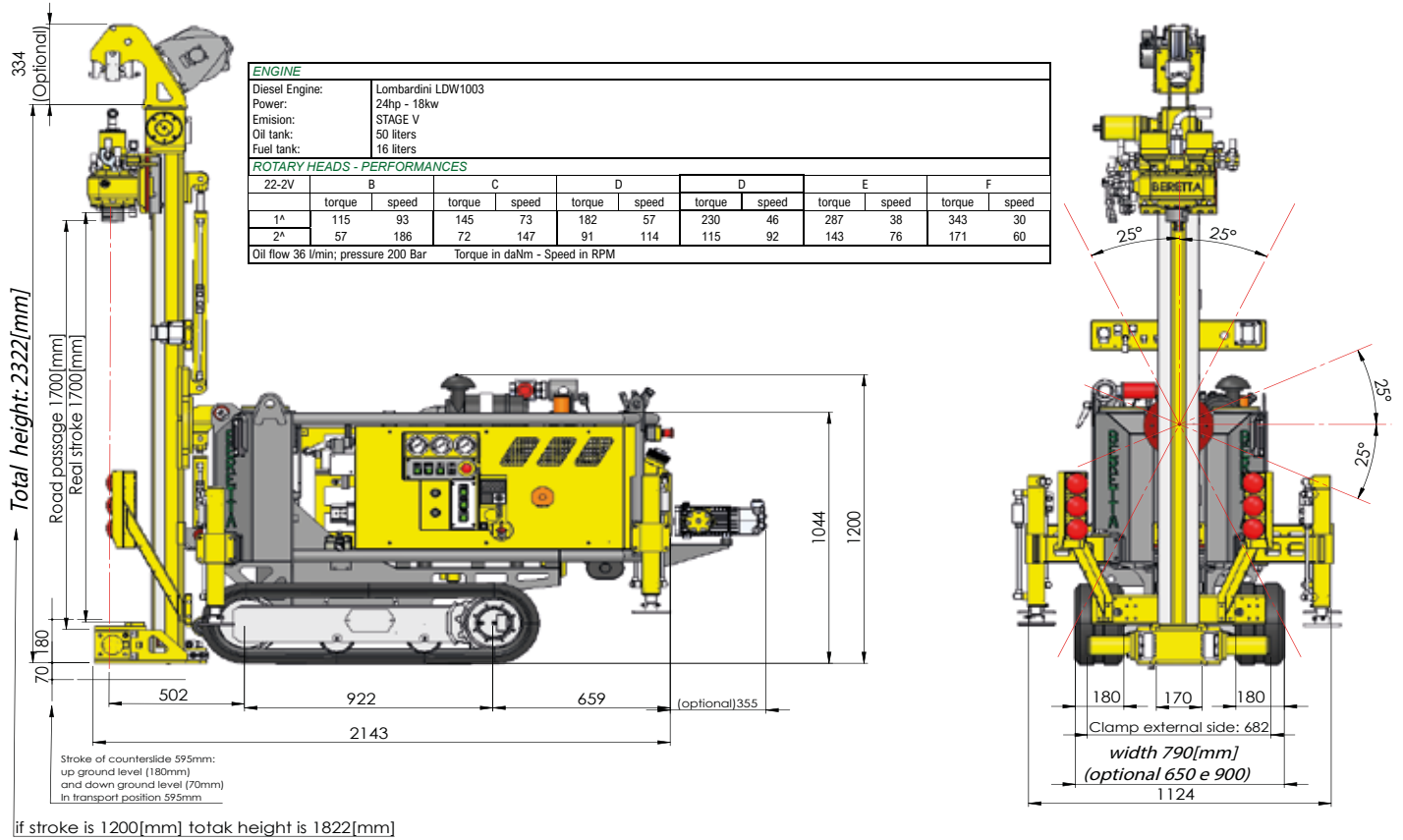

TRANSPORT DIMENSIONS

Weight: 1100 Kg (full opt. up to 1350 Kg)

